



**THE URBAN UNIT**

Urban Sector Planning & Management Services Unit (Pvt.) Ltd.  
A Public Sector Company.

**URBAN SECTOR PLANNING & MANAGEMENT  
SERVICES UNIT (PRIVATE) LIMITED**



**TENDER DOCUMENT  
For Purchase of Benches and Dustbins for Murree Mall  
Road  
(Single Stage One Envelope)**

(Note: Procurement is done by Urban Unit in line with PPRA Rules 2014)

**Tender # UU/2016-17/91**

**Tender Doc. Fee: Rs. 1000/- only  
(Rupees One Thousand Only)**



\_\_\_\_\_  
Sign & Stamp of bidder

*Amk*

*B*



## Table of Contents

TERMS & CONDITIONS.....	3
1. General.....	3
2. Time Period.....	3
3. Extension of Delivery period.....	3
4. Cancellation / Penalty of Delay .....	4
5. Payment to the Contractors .....	4
6. Bid Security .....	4
7. Deduction of Taxes .....	4
8. Dispute .....	4
9. Technical Evaluation Criteria .....	4
10. Financial Evaluation Criteria .....	4
11. Bid / Tender opening procedure.....	5
12. One person one bid.....	5
QUOTATION.....	7
BIDDER INFORMATION.....	1



Sign & Stamp of bidder

*(Handwritten signature)*

*AMK*



# THE URBAN UNIT

Urban Sector Planning & Management Services Unit (Pvt.) Ltd.  
A Public Sector Company.

## TERMS & CONDITIONS

Urban Sector Unit Planning & Management Services Unit (Pvt.) Limited (*hereinafter referred to as "The Urban Unit" or "Client"*) invites sealed bids from eligible and experienced income tax & sales tax registered firms / companies (*hereinafter referred to as "Bidder"*) for the specified items as per Annex-A (*hereinafter referred to as "goods"*).

### 1. **General:**

- 1.1 Any offer not received as per terms & conditions of the tender enquiry is liable to be ignored. No offer shall be considered if:
  - a) received without bid security
  - b) it is received after the time and date fixed for its receipt
  - c) not signed & stamped by authorized person on each page of tender document
  - d) the offer is ambiguous
  - e) the offer is received by fax or e-mail
  - f) the offer is from a black listed firm
  - g) offer received with shorter validity than required
  - h) the offer is not conforming to specifications indicated in the tender documents
  - i) the offer / quoted rates are furnished other than the tender documents
  - j) any additional terms & conditions added by the bidder
  - k) any conditional offer
- 1.2 Only Income & Sales tax registered firms / companies are eligible to participate in the tender.
- 1.3 Bid will remain valid for a period of 90 days from the date of opening the tender. No change in price will be made in case of Pak rupees variation against US\$ and any other case may be.
- 1.4 The cover envelop must indicate particulars of tender and date of opening. The envelope must be properly sealed.
- 1.5 Bidders have to participate for all items as mentioned at Annex-A. Partial bidding is not allowed.
- 1.6 Purchase Order(s) will be placed to overall lowest bidder(s) as per detailed at Annex-A.
- 1.8 The bidder must indicate their National Income Tax No. / Sales Tax No.
- 1.9 Offered rates will be on the basis of complete delivery and installation at Mall Road Murree and shall be inclusive of all taxes.
- 1.10 Purchase order will be issued by The Urban Unit after the approval of Competent Authority i.e. Chief Executive Officer of The Urban Unit.
- 1.11 The Urban Unit may increase or decrease the ordered quantity under Punjab Procurement Rules.

### 2. **Time Period:**

The bidder will have to complete the supply within **03-04 weeks** of the date of issuance of purchase order(s).

### 3. **Extension of Delivery period:**

- 3.1 In special circumstances, request for extension of delivery period may be considered by the Competent Authority on the written request of the firm before the target date of supply, who will be authorized to either accept or reject the request of bidder without assigning any reason.



\_\_\_\_\_  
Sign & Stamp of bidder

AMK



## THE URBAN UNIT

Urban Sector Planning & Management Services Unit (Pvt.) Ltd.  
A Public Sector Company.

4. **Cancellation / Penalty of Delay:**
  - 4.1 In case, bidder fails to execute the contract in accordance with the terms & conditions laid down in the tender document, bid security will be encashed and penalty @ 2% of total cost per week will be imposed up to a maximum of 10% of purchase order/work order value.
  - 4.2 The goods will be inspected by The Urban Unit through an authorized personnel and will be rejected, if not found according to the given specifications as mentioned at Annex – A and The Urban Unit will not be responsible for any costs or expenses incurred by the bidders in connection with the supply of goods.
5. **Payment to the Contractors:**
  - 5.1 Payment will be made through crossed cheque to the bidder against invoice after 100% completion of satisfactory supply of goods. No payment will be made as advance.
  - 5.2 Payment against partial supply of goods will not be made.
6. **Bid Security:**
  - 6.1 Bid security amount of **Rs. 75,000/-** will have to be attached along with tender document. It should be in the form of CDR from a scheduled bank in favor of Urban Sector Planning & Management Services Unit (Pvt.) Limited.
  - 6.2 Bid security of unsuccessful bidders shall be refunded on the finalization of the tender Whereas the bid security of successful bidder shall be refunded on the completion and successful delivery of PO.
  - 6.3 The bid security shall be forfeited if:
    - a. The offer is withdrawn, amended or revised.
    - b. The bidder fails to execute the contract strictly in accordance with terms and Conditions of tender document.
7. **Deduction of Taxes:**

Any taxes (if applicable) will be deducted while making payment as per Government Rules / Instructions/ Notifications. Bidder will be responsible for the payment of duties, levies and clearance from customs authorities etc.
8. **Dispute:**

In case of any dispute before or after the execution of contract, matter will be resolved as per PPRA Rules.
9. **Technical Evaluation Criteria:**
  - 9.1 NTN & GST registration is mandatory.
  - 9.2 Meet the required technical specifications of the items.
  - 9.3 Submission of colored pictures of similar samples of quoted items is mandatory for technical responsiveness.
  - 9.4 Financials of only technically responsive bidders shall be considered.
10. **Financial Evaluation Criteria:**
  - 10.1 The Financial of technically responsive bidders will be considered as lowest evaluated bidder.



Sign & Stamp of bidder

Amk



11. **Bid / Tender opening procedure:**  
As per PPRA Rules 2014, single stage one envelope bidding procedure shall be adopted.
12. **One person one bid:**
- 12.1 In any procurement, one person may submit one bid and if one person submits more than one bid, the procuring agency shall reject all such bids.
- 12.2 If a consortium of persons has submitted a bid in any procurement, it shall be construed that each member of the consortium submitted the bid

**DR. NASIR JAVED**  
**Chief Executive Officer**  
**Urban Sector Planning & Management**  
**Services Unit (Pvt.) Limited**



\_\_\_\_\_  
Sign & Stamp of bidder

Amic



TENDER CHECKLIST				
S. #	DESCRIPTION	Tick Yes / No		Documents Attached at Annexure
1	Copies of Purchase Orders (if any)			
2	Copy of the Proprietor's CNIC or firm			
4	Affidavit regarding non-involvement in any arbitration/ litigation with any government agency / department and not blacklisted as well.			
5	List of satisfied customers along with their contact numbers			
7	Copy of Income Tax Registration certificate			
8	Copy of Sales Tax Registrations certificate			
9	Colored Pictures of Similar Samples			

**Note:** Bidders must fill-up above mentioned checklist / table and attach copies of required documents with proper annexures along with tender document.



Sign & Stamp of bidder

Amk

B



**Annex-A**

**QUOTATION**

S. #	Item	Description	Qty.	Rate/Unit <sup>2</sup> (Incl. of all Taxes)	Total Price <sup>2</sup> (Incl. of all Taxes)
<b>BENCHES<sup>1</sup></b>					
1	<b>Bench Type. 1 Back &amp; Side Supports Benches</b>	Supply and fixing of red maranti wooden benches of approved color and size as per design and as shown on drawings consists of 2 Nos. of decorative galvanized wrought iron U-shape base supports and 2 Nos. of galvanized wrought iron side supports all components are fixed suitably for long use and to prevent damage during handling, transportation, and erection. all parts are joined together with galvanized nuts & bolts of suitable size and all bolts are sealed after assembly. Bench top and back planks are treated with polished and special anti-corrosive, water proof coating (epoxy coating) so as to make surfaces glossy and water proof. Complete in all respect and as directed by Engineer Incharge.	33		
2	<b>Bench Type. 2 Backless Benches</b>	Supply and fixing of backless red maranti wooden benches of approved color and size as per design and as shown on drawings consists of 2 Nos. of decorative galvanized wrought iron U-shape base supports, all components are fixed suitably for long use and to prevent damage during handling, transportation, and erection. all parts are joined together with galvanized nuts & bolts of suitable size and all bolts are sealed after assembly. Bench top and back planks are treated with polished and special anti-corrosive, water proof coating (epoxy coating) so as to make surfaces glossy and water proof. Complete in all respect and as directed by Engineer In charge.	30		
<b>Total Amount</b>					



Sign & Stamp of bidder

Amik





# THE URBAN UNIT

Urban Sector Planning & Management Services Ltd (Pvt) Ltd.  
A Public Sector Company.

S. #	Item	Description	Qty.	Rate/Unit <sup>2</sup> (Incl. of all Taxes)	Total Price <sup>2</sup> (Incl. of all Taxes)
<b>DUSTBINS<sup>1</sup></b>					
1	<b>Dustbin Type. 1 Round Shaped For Mall Road</b>	Providing and fixing of round shape 16 Swg steel body outdoor dustbins hanging between side posts as per design and as shown on drawings including puncture holes at bottom for water drainage and decorative galvanized wrought iron band around the dustbin perimeter at top, complete in all respect as per drawing and as directed by the Engineer Incharge.	36		
2	<b>Dustbin Type. 2 Square Shaped For Nighat Zar Park</b>	Providing and fixing of square type 16 Swg steel body outdoor dustbins fixed in ground as per design and as shown on drawings including decorative galvanized wrought iron around the dustbin, complete in all respect as per drawing and as directed by the Engineer Incharge.	24		
<b>Total Amount</b>					
<b>GRAND TOTAL</b>					
<b>Amount in Words:</b>					

1-The successful bidder after issuance of the Purchase Order will deliver one sample of each item to the Urban Unit office, Lahore for approval of Client in all respects before production of remaining quantity.

2- Amount shall be inclusive of transportation, installation and all applicable taxes.



Sign & Stamp of bidder

AMK

B







REFERENCE IMAGE

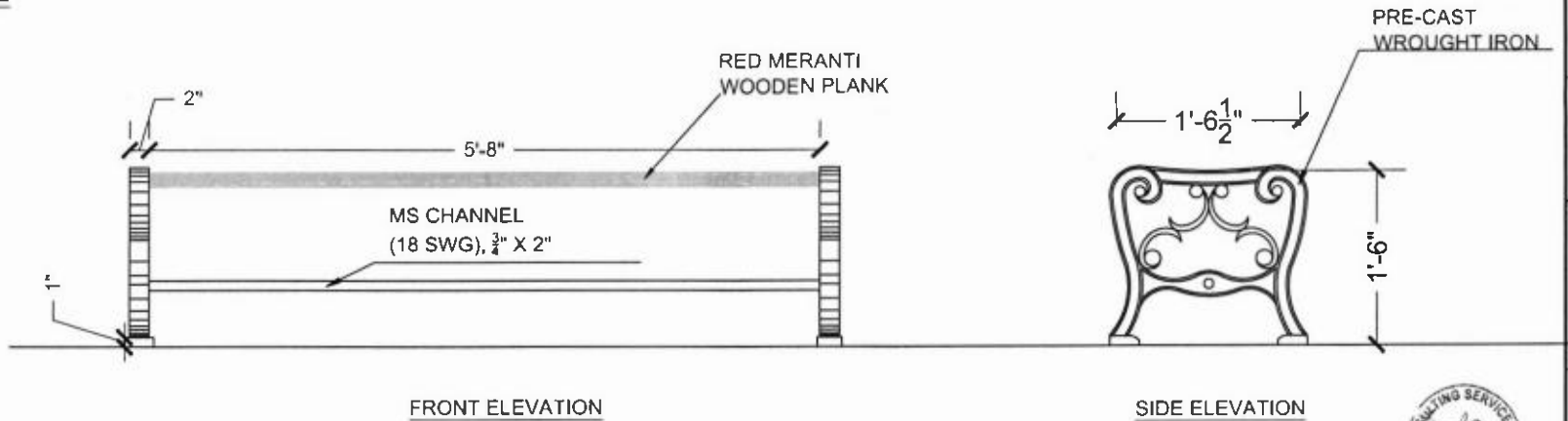

Sign & Stamp of bidder

REV. NO.	DATE	BY	CHKD	REMARKS	DESIGNED BY: [Signature] DRAWN BY: [Signature] CHECKED BY: [Signature] APPROVED BY: [Signature]	<b>THE URBAN UNIT</b> ARCHITECTS, ENGINEERS AND PLANNERS CONSULTANTS 5 Public Sector Company	<b>UNICOR</b> CONSULTING SERVICES PVT. LTD. ARCHITECTS, ENGINEERS AND PLANNERS CONSULTANTS 503 - Shaheen Complex, Egerton Road, Lahore - Ph: 042-99205316-22 Fax: 042-99205323, Web: www.urbanunit.gov.pk	PROJECT NAME: <b>RESTORATION &amp; UPGRADATION OF MALL ROAD MURREE</b>	PROJECT COMPONENT: <b>MALL ROAD DUSTBIN AND BENCHES</b>	DRAWING TITLE: <b>BENCH TYPE 2</b>	SHEET NO.: <b>A-405a</b>
----------	------	----	------	---------	--	--	---	---	--	---------------------------------------	-----------------------------

TENDER DRAWING

*Amk*



REFERENCE IMAGE

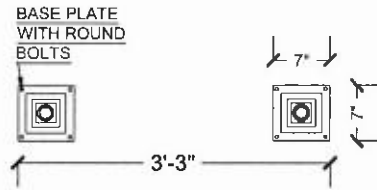

POSTS

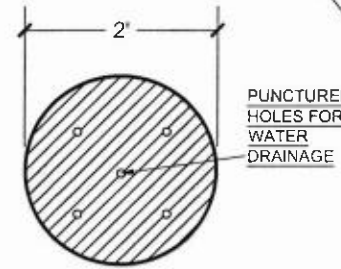

SECTIONAL PLAN  
16 SWG MS SHEET WITH  
PUNCTURED HOLES FOR  
WATER DRAINAGE

DECORATIVE PATTERN MADE IN  
WROUGHT IRON  
BAND AROUND DUSTBIN PERIMETER

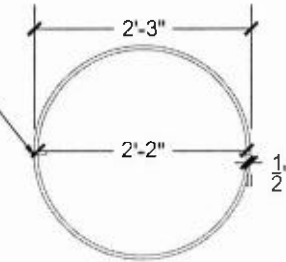

DECORATIVE  
BAND

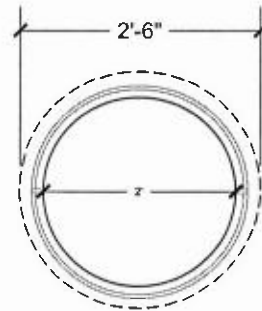

STEEL BARREL WITH LID  
AND DECORATIVE BAND

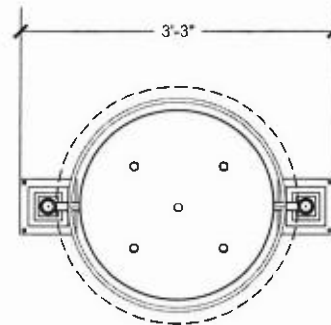

PLAN

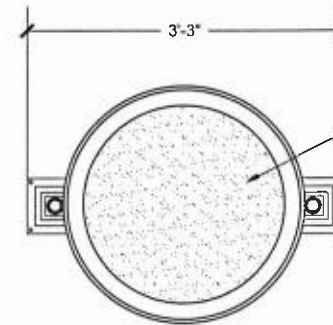

TOP PLAN  
WITH LID

ASHTRAY LID  
COVERED  
WITH SAND



Sign & Stamp of bidder

NO.	DATE	BY	CHKD	REMARKS

DESIGNED BY: WALEED  
 DRAWN BY: AYESHA  
 CHECKED BY: ID  
 APPROVED BY: ID  
 DATE: 20-12-2018

ENGINEERS, ARCHITECTS AND  
PLANNING CONSULTANTS

PROJECT NAME:  
RESTORATION & UPGRADATION  
OF MALL ROAD MURREE

PROJECT COMPONENT:  
MALL ROAD  
DUSTBIN AND BENCHES

DRAWING TITLE:  
DUSTBIN TYPE 1  
PLAN

SHEET NO.  
A-402c

TENDER DRAWING

*Amik*

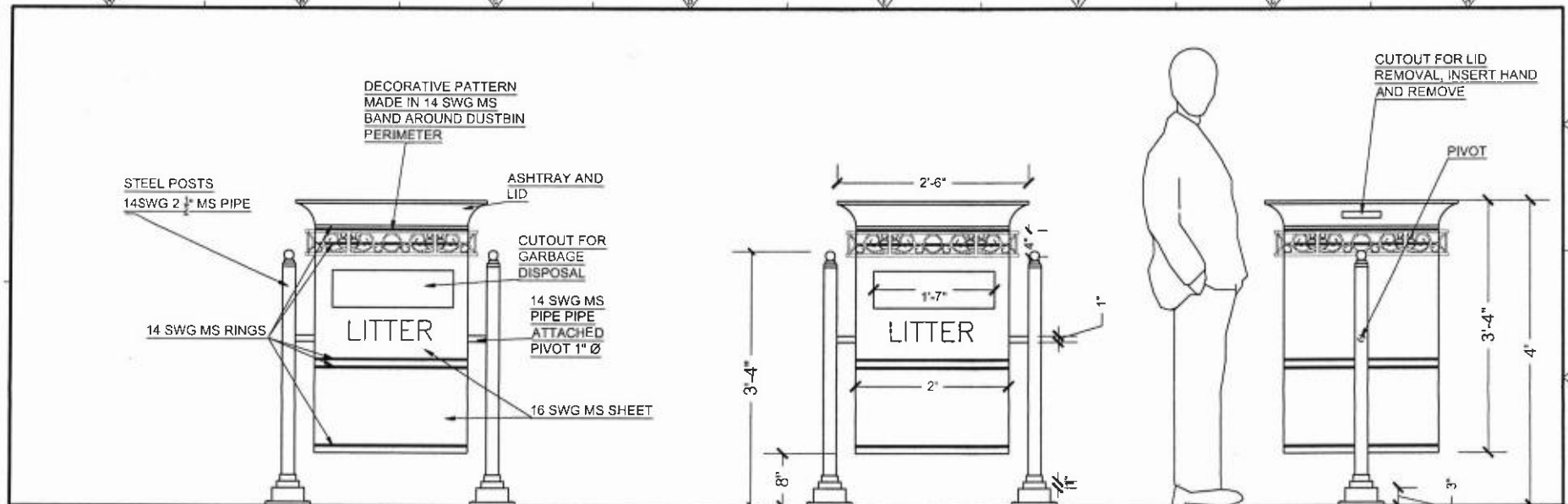

FRONT ELEVATION

FRONT ELEVATION

SIDE ELEVATION

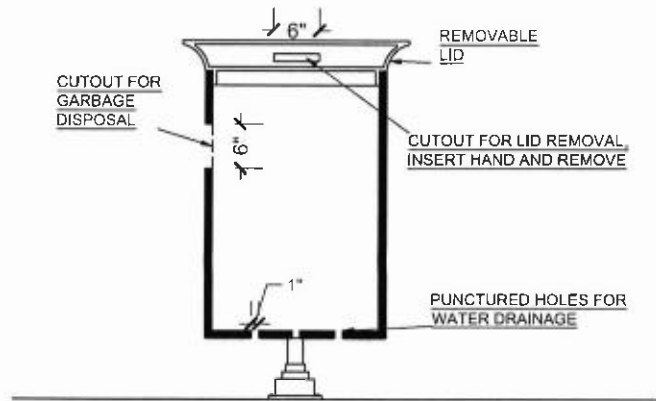

SIDE SECTION

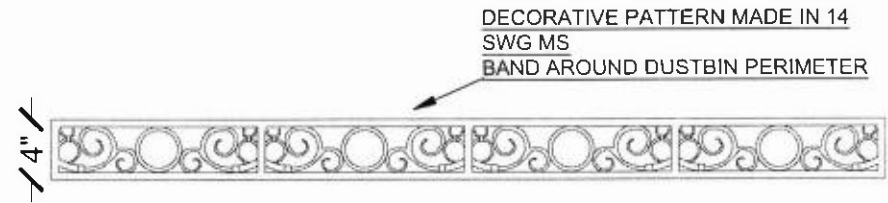

Sign & Stamp of bidder

REV. NO.	DATE	CRWN	CHNG	REMARKS	DESIGNED BY: <u>TD</u>	 <b>THE URBAN UNIT</b> <small>Urban Sector, Housing &amp; Management Services for the Urban</small> <small>A Public Sector Company</small>	 <b>Uni-on</b> <small>ARCHITECTS, ENGINEERS AND PLANNING CONSULTANTS</small> <small>100-A, Sector 11, F-7/1, Islamabad</small>	PROJECT NAME:	PROJECT COMPONENT:	DRAWING TITLE:	SHEET NO.
					DATE: 20-12-2019			RESTORATION & UPGRADATION OF MALL ROAD MURREE	MALL ROAD DUSTBIN AND BENCHES	DUSTBIN TYPE 1 ELEVATIONS AND DETAILS	A-402d

TENDER DRAWING

*Amk*

# GARBAGE REMOVAL MECHANISM PIVOT SYSTEM

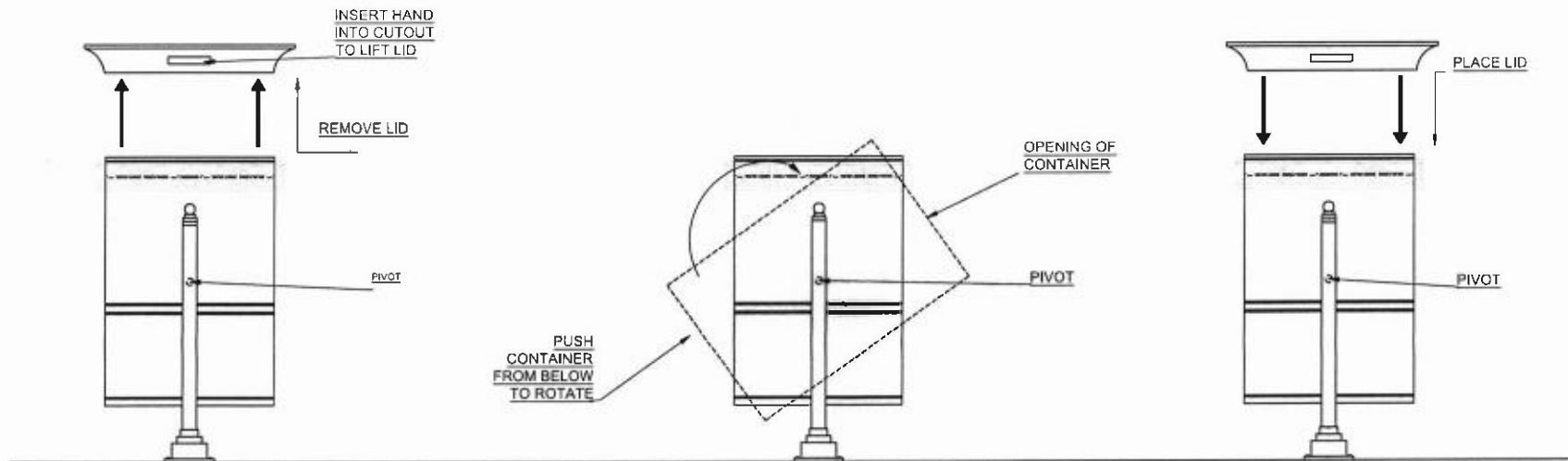

SIDE ELEVATION

SIDE ELEVATION  
GARBAGE REMOVAL STEP 1

SIDE ELEVATION  
GARBAGE REMOVAL STEP 2

SIDE ELEVATION  
GARBAGE REMOVAL STEP 3



Sign & Stamp of bidder

NO.	DATE	BY	CHKD	REMARKS	DESIGNED BY: SYDIP DRAWN BY: SYDIP CHECKED BY: FO APPROVED BY: FO DATE: 02-12-2018	 <b>THE URBAN UNIT</b> <small>11 New Moon Plaza, Margalla Hills, Islamabad</small> <small>ARCHITECTS, ENGINEERS AND PLANNING CONSULTANTS</small> <small>110, Street 06, G-7/1, F-7/1, Islamabad</small>	 <b>UNICON</b> <small>ARCHITECTS, ENGINEERS AND PLANNING CONSULTANTS</small> <small>110, Street 06, G-7/1, F-7/1, Islamabad</small>	PROJECT NAME: <b>RESTORATION &amp; UPGRADATION OF MALL ROAD MURREE</b>	PROJECT COMPONENT: <b>MALL ROAD DUSTBIN AND BENCHES</b>	DRAWING TITLE: <b>DUSTBINS GARBAGE DISPOSAL MECHANISM</b>	SHEET NO.: <b>A-402e</b>
-----	------	----	------	---------	--	---	---	---	--	--	-----------------------------

TENDER DRAWING

*Amir*



REFERENCE IMAGE

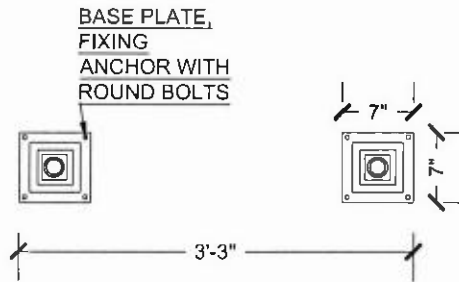

POSTS

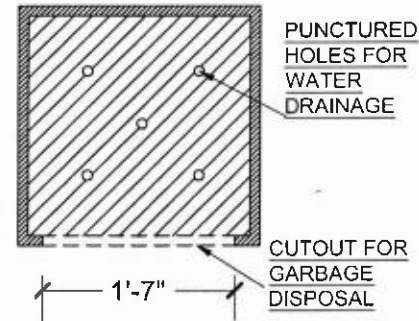

SECTIONAL PLAN

STEEL BARREL WITH PUNCTURED HOLES FOR WATER DRAINAGE

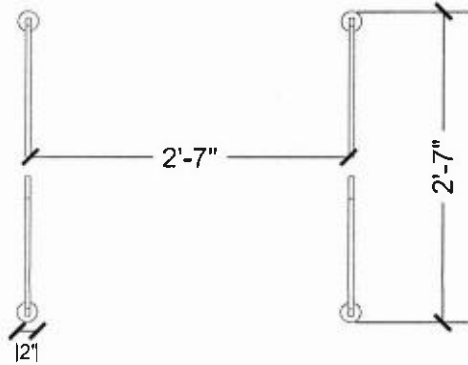

DECORATIVE PATTERN  
MADE IN 14 SWG MS  
BAND ON DUSTBIN SIDES

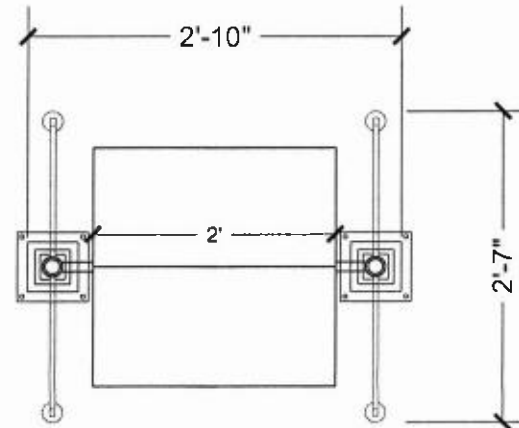

STEEL BARREL WITH LID  
AND DECORATIVE BAND



Sign & Stamp of bidder

DESIGNED BY: <u>TD</u>	THE URBAN UNIT Architectural, Engineering & Planning Consultants A Public Sector Enterprise	PROJECT NAME: RESTORATION & UPGRADATION OF MALL ROAD MURREE	PROJECT COMPONENT: MALL ROAD DUSTBIN AND BENCHES	DRAWING TITLE: DUSTBIN TYPE 2 NIGHT ZAR PARK ONLY	SHEET NO: A-402I
DRAWN BY: <u>ZARSH</u>	UNICOR CONSULTING SERVICES (PVT) LTD. LAHORE				
CHECKED BY: <u>ASIM</u>					
APPROVED BY: <u>TD</u>					
DATE: 20-12-2015					

TENDER DRAWING

*Ank*